

Hydro Stock Zenoah 26 Regulations

Issued by the iMBRA Committee, valid from January 2025

A) The Hydro Stock Zenoah 26 class runs with sport hydros that are free build models with three or more planing surfaces with the following specifications:

- 1) Sport Hydro boats shall have a design and appearance as the US Unlimited or Limited race boats with all planing surfaces placed under the hull's front half. (the first 50% part of the hulls total length). The boats propulsion system and propeller is excepted from this rule.
- 2) Double rudder - and twin propeller arrangements are not permitted.
- 3) The bottom at the rear end of the hull, i.a. the distance from the rear end of the pontoons or planing surfaces where they are mounted to the hull – (C in the figure below)- must not exceed 60% of the total length of the hull.
- 4) Minimum width at the rearmost part of the stern (D in figure 1) must not be less than 7" (190,5mm)
- 5) If the Sport Hydro is of the "pickle fork" design with a front wing - figure 1 – the sum of (A) and (B) must not exceed 25% of the total length of the hull.

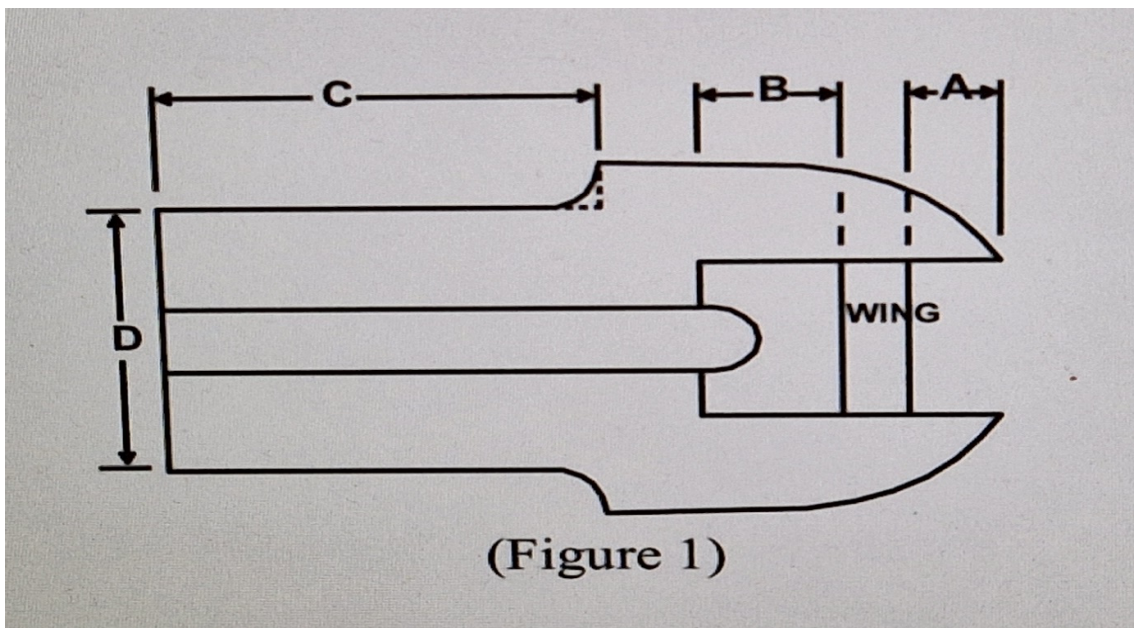

B) Engine specifications:

As specified in the iMBRA Stock Zenoah Regulations

C) Heat racing rules and race duration:

According to the general iMBRA heat racing rules, but with a 12-lap heat duration. The 12 laps must be completed within 8 minutes to achieve approved race points.